

RW-110 WIND ENERGY SYSTEM EXPERIMENT SET



Wind energy is renewable energy type which is an important subject in the world today. This is a modular type experiment set. The location of the modules can be changed. With safe electrical cables these modules are connected. There are wind tunnel and wind turbine on the set. There is a siren, fan and lamp which are functioning with the produced energy. DC current and AC current can be produced. For that an inverter is used. The amperage, voltage and other sensor value can be read directly on the data screen.

The students can make with this experiment set; application of a wind turbine and wind power and efficiency values determining experiments.

The system is used for observation and experimenting the behaviour of wind energy generation under various effects and to study the conversion of kinetic wind energy into electric energy. The components of the modular system ensure that the effects of the variables such as, angle and speed of air, influence of the load variation, voltage and current and power output are observed. The module instruments and sensors are monitored real time by software over a PC with simulation capabilities or PLC or SCADA with HMI panel. The system software enable network functionality as described.

Power coefficient value and efficiency of the power plant are measurable with the components of the system.

Conversion and consumption simulation are realised with the system.

The system have wind tunnel unit which includes axial fan unit, air speed sensor, rotor speed sensor mounted inside and entry of the tunnel (depending on the sensor type), aero generator with 6 blades in protective metal housing.

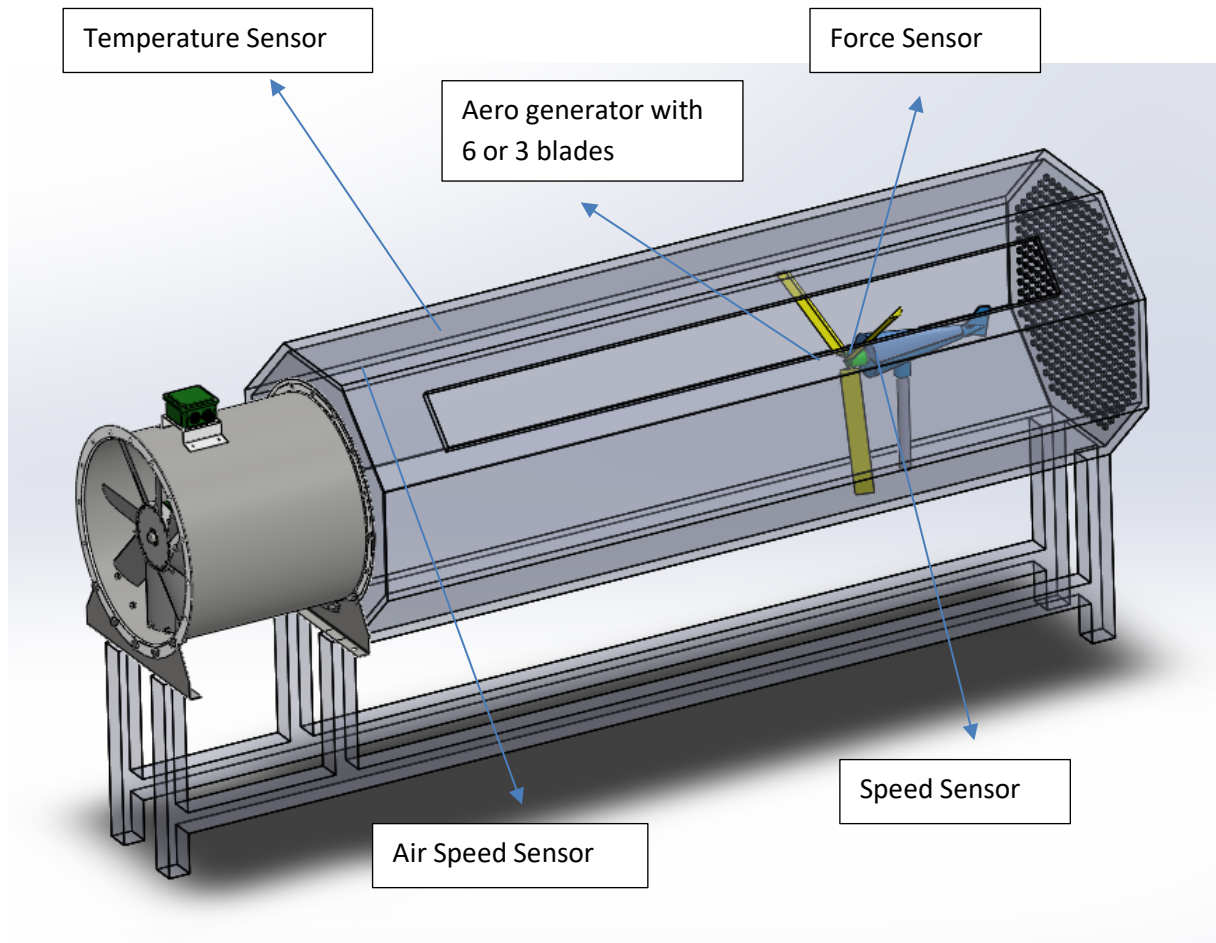

Layout of the system showing wind tunnel, sensors in tunnel, modules, controllers and measuring points.

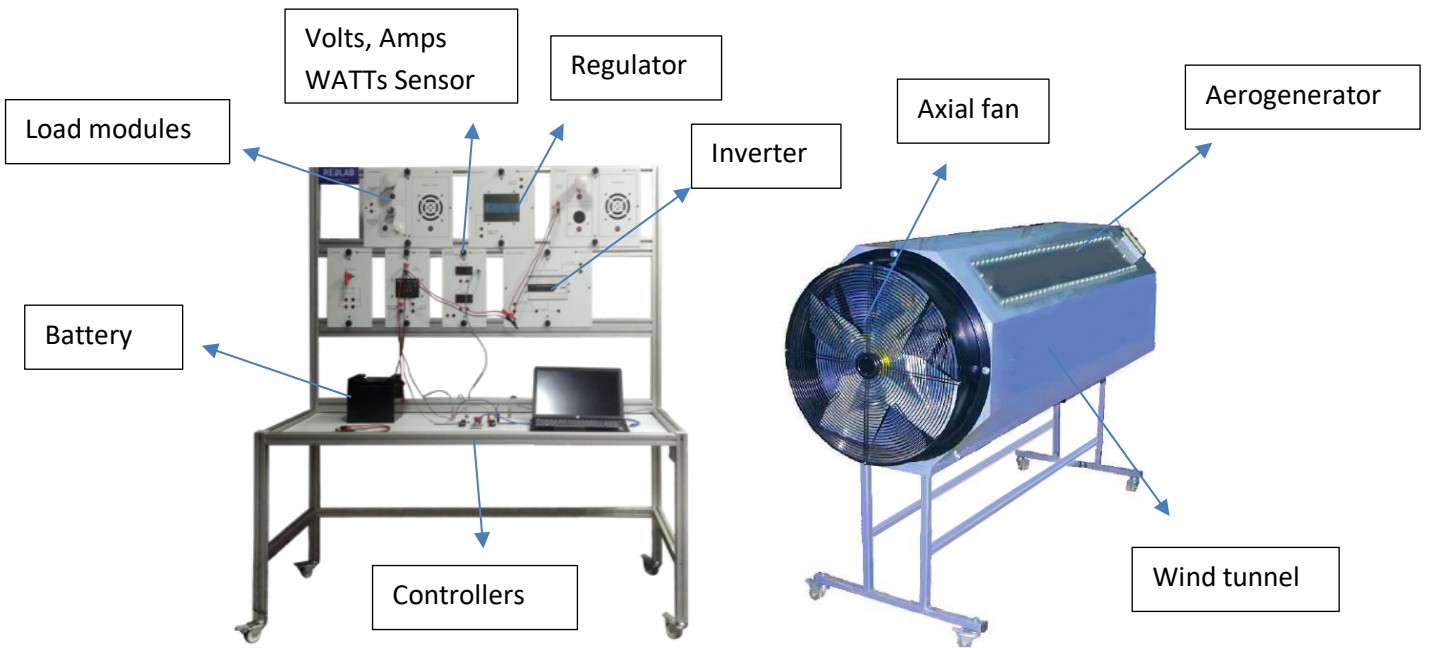

The unit includes:

- Stainless steel tunnel
- Aerogenerator
- Axial fan with variable speed
- DC Load Regulator
- Auxiliary battery charger
- Battery
- DC Loads Module
- Sensors

Sensors:

- “J” type temperature sensor to measure the air temperature inside of the tunnel.
- The air speed is measured with a sensor placed in the tunnel; sensor range: 0.20 – 10 m/s.
- An optical sensor measures the rotational speed of the aerogenerator (r.p.m.).
- DC voltage and current sensor. It is possible to know, in real time, the value of the DC voltage and the current given by aerogenerator, measured before and after the regulator.
- Force sensor to measure the mechanical torque of the wind turbine, range: 0 – 600 g.
- Force sensor to measure the thrust force on the wind turbine, range: 0 – 3000 g.

Axial fan is able to generate air flow required for the wind energy unit.

For simulation of different wind conditions it is either possible to adjust blade configuration such as adjusting number of blades or angle of blades or alternatively by varying wind velocity through rotational speed of fan (fan speed is adjustable).

The wind tunnel is stainless steel with a dimension of (LxWxH): 2500x800x800mm. Consistent wind conditions is ensured by the system.

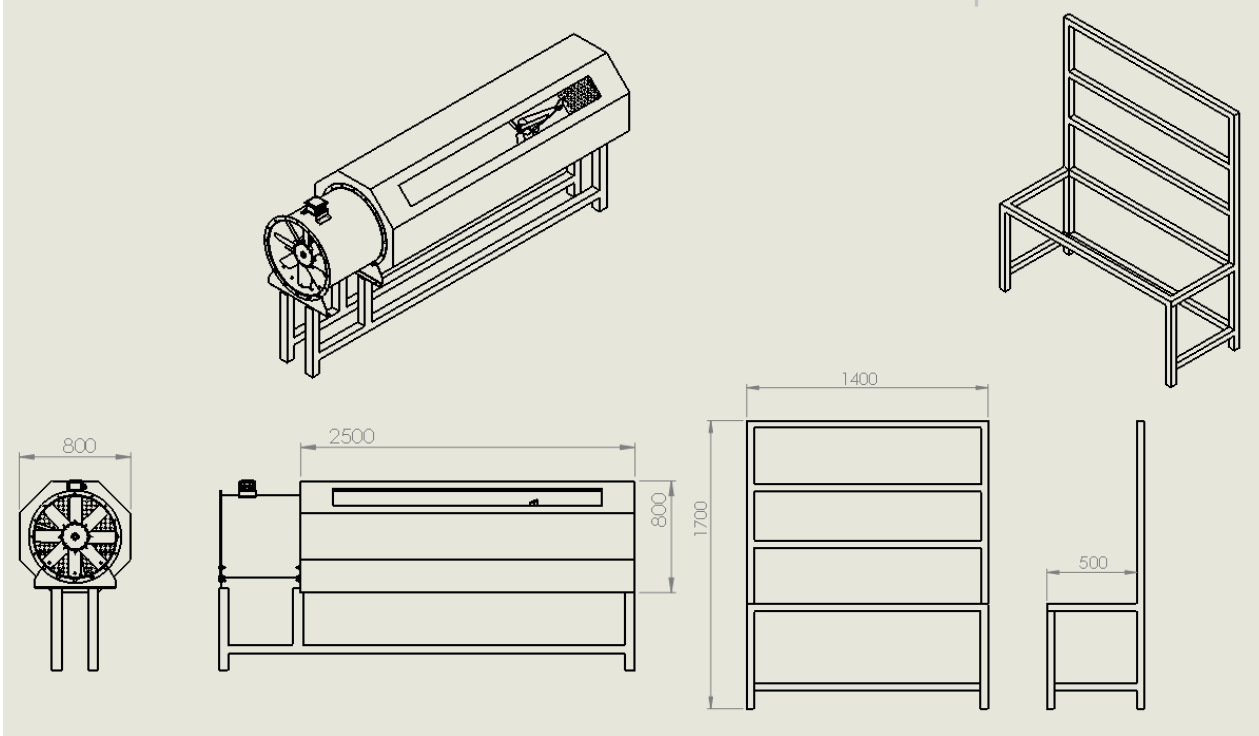

System Components:

- Mobile metallic carriage trolley table for sensors, battery, regulator and control unit and for wind tunnel
- Stainless steel wind tunnel with components and axial fan
- Axial fan controller
- Battery and charge controller
- DC and AC Loads module
- Inverter
- Sensors measuring current, voltage, wind velocity, rotor speed as minimum
- Connections for data acquisition and real time display of the measured values
- Software and PC for monitoring and adjusting system components
- Other auxiliary connections, modules and cabling if needed for operation of the equipment.

Axial fan specifications:

- Flow rate: 10.000 m³/h.
- Maximum power: 1.5 kW.
- have finger guard or protective cage.

Aero generator specifications:

- Rotor diameter range: 500-600mm.
- Maximum output: 60W.
- Voltage: 12V
- Max changing current: 5A

The battery have 12V and a rated capacity of 8 Ah. There is a charger assessing the battery and provides the charge when needed.

The system have DC loads module with two 12V lamps and load connections are switchable.

There are a DC voltage and current sensor with are able to measure up to 15VDC and 20A.

Air speed sensor is able to measure up to 10 m/s.

Rotor speed sensor is able to measure up to 1.500 rpm.

There is a single phase inverter. It have short-circuit and overcharge protection.

It is possible to connect the system to with grid connection inverter, or if grid connection is not possible, an optional connection to an external consumer is applicable.

The system have control interface and data acquisition system to display sensor information and values with the PC software. The system ensure that the user can control parameters involved in the process in real time. PC have PCI Express Data acquisition board if necessary for fulfilments of the requirements.

The software ensure simultaneous visualization of all parameters involved in the process and modification of the actuators.

Scada Software:

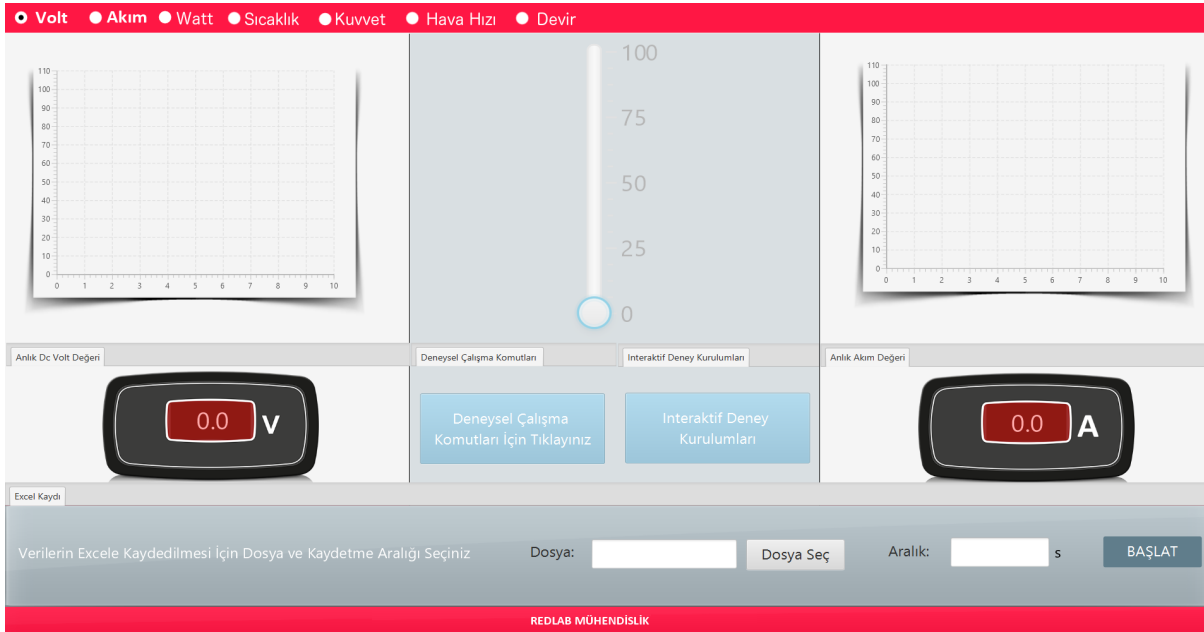

All cables, modules, data acquisition system, software and related accessories required for fully operation of the system are provided. The components are integrated to each other over the carriage trolley and monitored via software.

The system comply with CE Marking and conformity declarations are provided.

Symbols for the relevant equipment or circuit diagrams conforming to latest DIN/ISO standards are screen-printed on the front panel of the modules. If necessary, front panels are supplemented with colour graphics or photographs at applicable locations on the panels/modules.